

WLAN-A0015

Packing Check List

Item	Description	Quantity
For WLAN-A0015 (standard version)		
1.	WLAN-A0015 enclosure with integrated 16dBi antenna	1
2.	Stand-off pillars (Inside enclosure)	6
3.	M6 x 16mm Bolt – SS (Inside enclosure)	4
4.	M6 external star washer – SS (Inside enclosure)	4
5.	No.6 x 9.5mm - Self Tapping Screws – Galv. (Inside enclosure)	6
6.	M4 - Washers, Flat SS (Inside enclosure)	6
8.	M16 Gland with nut (attached to enclosure)	1
Universal Bracket Kit (Aluminium) - (ordered separately)		
9.	Universal Bracket (Aluminium)	1
10.	M6 x 90mm U-Bolt SS	2
11.	Econo bracket	2
12.	M6 Flat Washer SS	4
13.	M6 Nut SS	4

Installation Instructions

Installing Electronics

1. Unscrew the back of the enclosure and carefully lift off the lid containing the integrated antenna (refer to figure 1).
2. Use the provided screws and washers (items 5 and 6) to secure the stand-off pillars to the electronics you wish to install. Be sure that the height of electronics and pillars does not exceed 40mm (refer to figure 2).
3. Peel off the adhesive backing paper from the base of the pillars and secure the pillars to the back of the lid (refer to figure 3). Ensure that the electronics is located such that the antenna cable can be connected easily.
4. Connect the antenna to the electronics either directly with the SMA(f) connector or by means of an adaptor cable (not provided) as necessary (refer to figure 4).

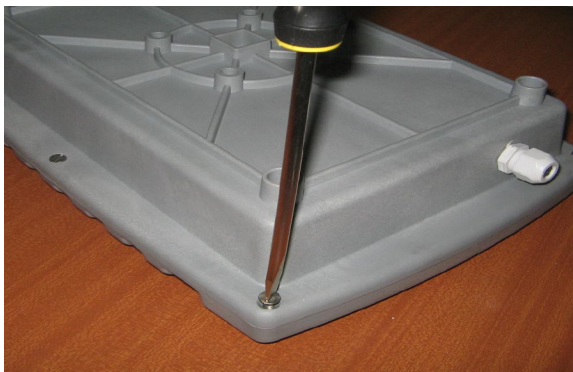

Figure 1. Unscrew enclosure.

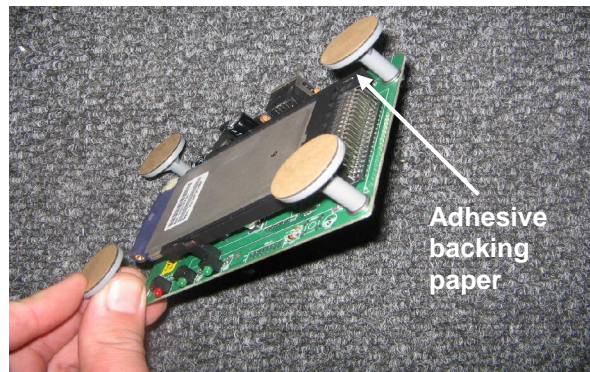

Figure 2. Secure the stand-off pillars.



Figure 3. Attach electronics to back of lid and connect the antenna

Installing CAT-5 cable

1. The enclosure is provided with a watertight gland that allows the installation of CAT-5 cable (not provided) as necessary.
2. Insert one end of the desired length of CAT-5 cable through the gland and into the enclosure with the locking nut loosened.
3. Ensure a sufficient length of cable is available in the enclosure to allow connection to the electronics as necessary before tightening the locking nut on the gland to secure and water seal the cable. (Hint: allow enough cable inside the enclosure to facilitate maintenance and replacement of electronics in future).
4. Using a crimping tool, secure the appropriate connector to the CAT-5 cable inside the enclosure and connect to the electronics.
5. Power over ethernet (POE) can be sent through the CAT-5 cable using the appropriate injector and DC supply (both not provided) for the chosen electronics.



Figure 5. Insert cable through gland



Figure 6. Secure connector to the cable

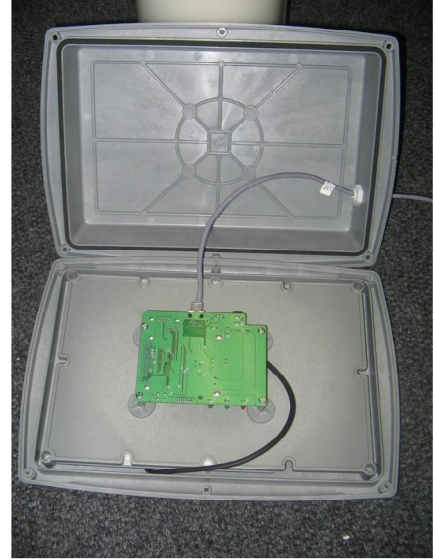

Figure 7. Connect to electronics

Mounting the enclosure

1. The enclosure can be mounted for either vertical or horizontal polarisation. Refer to polarisation sticker on the back of the enclosure.
2. Attach the L bracket to the antenna by means of the four M6 x 16mm bolts provided. The figure 8 illustrates this for vertical polarisation.
3. Attach the enclosure to a mast (diameter 40-50mm) using the Econo-bracket assembly as shown in figure 8.
4. The Econo-bracket can be mounted through different holes to achieve the desired tilt angle of the antenna. (see figure 9).

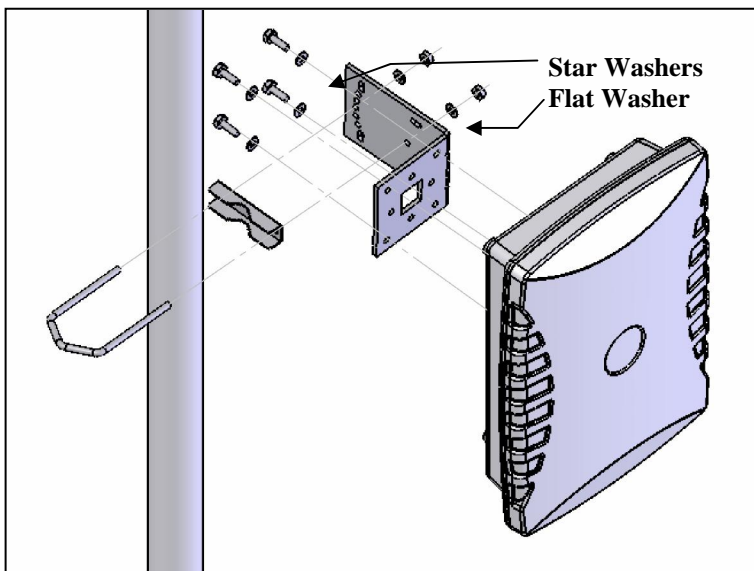

Figure 8. Mast mounting

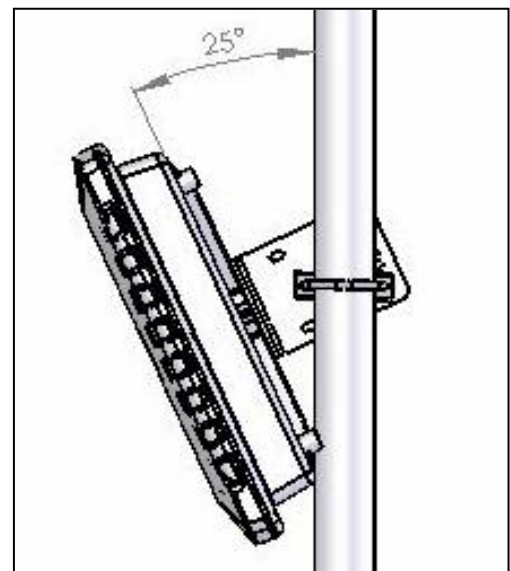

Figure 9. Setting tilt angle